



BURÇLU V KASNAKLAR / V PULLEYS FOR TAPER BUSHES



SPZ (10 mm) BURÇLU V KASNAKLAR
SPZ (10 mm) V PULLEYS FOR TAPER BUSHES



SPA (13 mm) BURÇLU V KASNAKLAR
SPA (13 mm) V PULLEYS FOR TAPER BUSHES



SPB (17 mm) BURÇLU V KASNAKLAR
SPB (17 mm) V PULLEYS FOR TAPER BUSHES



SPC (22 mm) BURÇLU V KASNAKLAR
SPC (22 mm) V PULLEYS FOR TAPER BUSHES



BURÇLU V KASNAKLAR V PULLEYS FOR TAPER BUSHES

DIN 2211 STANDARTINDA V KASNAK KANALI ÖLÇÜLERİ V PULLEY GROOVES DIMENSIONS AT DIN 2211 STANDARTS

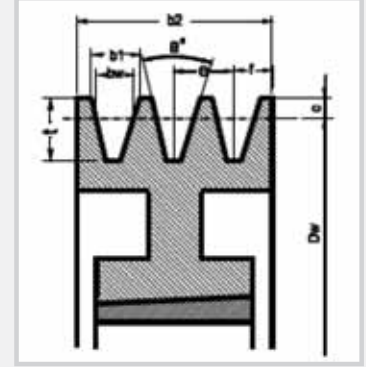

TİP / TYPES	SPY	SPZ	SPA	SPB	SPC	SPD	SPE
V KAYIŞ/V BELT	6	10	13	17	22	32	38
b1	6,3	9,7	12,7	16,3	22	32,7	38,7
C	1,6	2	2,8	3,5	4,8	8,1	9,6
E	8	12	15	19	25,5	37	44,5
F	6	8	10	12,5	17	24	29
T Min.	7,9	11	14	18	24	33	38
a°=32∞	DW←60						
a°=34∞		DW←80	DW←118	DW←190	DW←315		
a°=36∞	DW→60					DW←475	DW←475
a°=38∞		DW→80	DW→118	DW→190	DW→315	DW→475	DW→475



KANAL SAYISI VE KAYIŞ TİPİNE GÖRE b2 GENİŞLİK ÖLÇÜLERİ (mm) THE WIDTH DIMENSION (b2) ACCORDING TO THE GROOVE NUMBER AND BELT TYPE

KANAL GROOVE	SPY	SPZ	SPA	SPB	SPC	SPD	SPE
1	12	16	20	25	34	46	56
2	20	28	35	44	59,5	83	100,5
3	28	40	50	63	85	120	145
4	36	52	65	82	110,5	157	189,5
5	0	64	80	101	136	194	234
6	0	76	95	120	161,5	231	278,5
8	0	0	0	158	212,5	305	367,5
10	0	0	0	196	263,5	379	456,5
12	0	0	0	234	314,5	543	545,5
14	0	0	0	272	365,5	527	634,5
16	0	0	0	310	416,5	601	723,5
18	0	0	0	348	467,5	675	812,5

BURÇLU V KASNAKLAR
V PULLEYS FOR TAPER BUSHES
SPZ (10 mm) BURÇLU V KASNAKLAR / SPZ (10 mm) V PULLEYS FOR TAPER BUSHES

Birim / Unit : mm

Kod Code	Anma Çapı Nominal Dia. Do	Dış Çapı Outer Dia. Da	Kanal No Groove	Burç No Bush	Max. Delik Max. Bore	Kasnak Tipi Pulley Type	F	L
SPZ 50/1	50	54	1	1008	25	8	16	22
50/2	50	54	2	1008	25	8	28	22
SPZ 56/1	56	60	1	1008	25	8	16	22
56/2	56	60	2	1008	25	8	28	22
SPZ 60/1	60	64	1	1008	25	1	16	22
60/2	60	64	2	1008	25	8	28	22
SPZ 63/1	63	67	1	1108	28	1	16	22
63/2	63	67	2	1108	28	8	28	22
63/3	63	67	3	1108	28	8	40	22
SPZ 67/1	67	71	1	1108	28	1	16	22
67/2	67	71	2	1108	28	8	28	22
67/3	67	71	3	1108	28	8	40	22
SPZ 71/1	71	75	1	1108	28	1	16	22
71/2	71	75	2	1108	28	8	28	22
71/3	71	75	3	1108	28	8	40	22
SPZ 75/1	75	79	1	1108	28	1	16	22
75/2	75	79	2	1210	32	8	28	25
75/3	75	79	3	1210	32	8	40	25
SPZ 80/1	80	84	1	1210	32	1	16	25
80/2	80	84	2	1210	32	8	28	25
80/3	80	84	3	1210	32	8	40	25
80/4	80	84	4	1210	32	8	52	25
SPZ 85/1	85	89	1	1210	32	1	16	25
85/2	85	89	2	1610	42	8	28	25
85/3	85	89	3	1610	42	8	40	25
85/4	85	89	4	1610	42	8	52	25
85/5	85	89	5	1610	42	8	64	25
SPZ 90/1	90	94	1	1210	32	1	16	25
90/2	90	94	2	1610	42	8	28	25
90/3	90	94	3	1610	42	8	40	25
90/4	90	94	4	1610	42	8	52	25
90/5	90	94	5	1610	42	8	64	25
90/6	90	94	6	1610	42	8	72	25
SPZ 95/1	95	99	1	1210	32	1	16	25
95/2	95	99	2	1610	42	8	28	25
95/3	95	99	3	1610	42	8	40	25
95/4	95	99	4	1610	42	8	52	25
95/5	95	99	5	1610	42	8	64	25

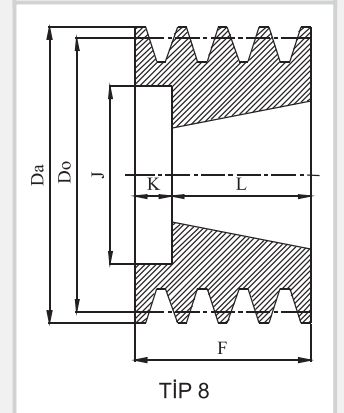
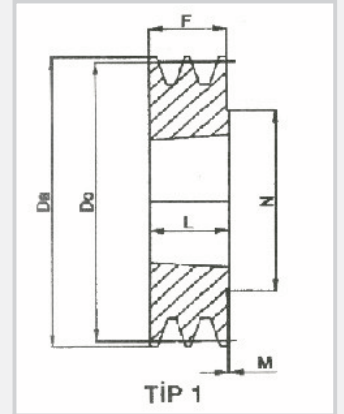



BURÇLU V KASNAKLAR
V PULLEYS FOR TAPER BUSHES

SPZ (10 mm) BURÇLU V KASNAKLAR / SPZ (10 mm) V PULLEYS FOR TAPER BUSHES

Birim / Unit : mm

Kod Code	Anma Çapı Nominal Dia. Do	Dış Çapı Outer Dia. Da	Kanal No Groove	Burç No Bush	Max. Delik Max. Bore	Kasnak Tipi Pulley Type	F	L
SPZ 100/1	100	104	1	1210	42	1	16	25
100/2	100	104	2	1610	42	8	28	25
100/3	100	104	3	1610	42	8	40	25
100/4	100	104	4	1610	42	8	52	25
100/5	100	104	5	2012	50	8	64	32
100/6	100	104	6	2012	50	8	76	32
SPZ 106/1	106	110	1	1610	42	1	16	25
106/2	106	110	2	1610	42	8	28	25
106/3	106	110	3	1610	42	8	40	25
106/4	106	110	4	1610	42	8	52	25
106/5	106	110	5	2012	50	8	64	32
106/6	106	110	6	2012	50	8	76	32
SPZ 112/1	112	116	1	1610	42	1	16	25
112/2	112	116	2	1610	42	8	28	25
112/3	112	116	3	2012	50	8	40	32
112/4	112	116	4	2012	50	8	52	32
112/5	112	116	5	2012	50	8	64	32
112/6	112	116	6	2012	50	8	76	32
SPZ 118/1	118	122	1	1610	42	1	16	25
118/2	118	122	2	1610	42	8	28	25
118/3	118	122	3	2012	50	8	40	32
118/4	118	122	4	2012	50	8	52	32
118/5	118	122	5	2012	50	8	64	32
118/6	118	122	6	2012	50	8	76	32
SPZ 125/1	125	129	1	1610	42	1	16	25
125/2	125	129	2	1610	42	8	28	25
125/3	125	129	3	2012	50	2	40	32
125/4	125	129	4	2012	50	2	52	32
125/5	125	129	5	2012	50	8	64	32
125/6	125	129	6	2517	50	8	76	45
SPZ 132/1	132	136	1	1610	42	1	16	25
132/2	132	136	2	1610	42	8	28	25
132/3	132	136	3	2012	50	2	40	32
132/4	132	136	4	2012	50	2	52	32
132/5	132	136	5	2517	50	8	64	45
132/6	132	136	6	2517	50	8	76	45

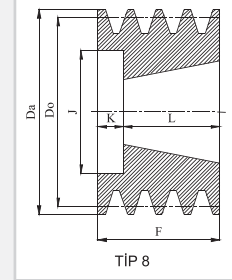
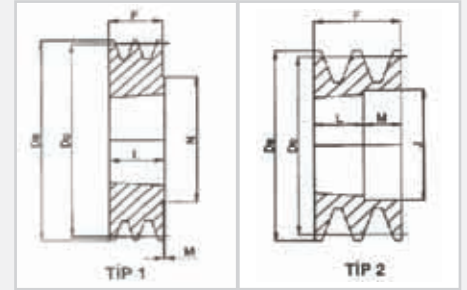

BURÇLU V KASNAKLAR
V PULLEYS FOR TAPER BUSHES
SPZ (10 mm) BURÇLU V KASNAKLAR / SPZ (10 mm) V PULLEYS FOR TAPER BUSHES

Birim / Unit : mm

Kod Code	Anma Çapı Nominal Dia. Do	Dış Çapı Outer Dia. Da	Kanal No Groove	Burç No Bush	Max. Detik Max. Bore	Kasnak Tipi Pulley Type	F	L
SPZ 140/1	140	144	1	1610	42	1	16	25
140/2	140	144	2	2012	42	8	28	32
140/3	140	144	3	2012	50	2	40	32
140/4	140	144	4	2517	50	2	52	45
140/5	140	144	5	2517	60	2	64	45
140/6	140	144	6	2517	60	2	76	45
140/8	140	144	8	2517	60	3	100	45
SPZ 150/1	150	154	1	1610	42	1	16	25
150/2	150	154	2	2012	50	1	28	32
150/3	150	154	3	2012	50	2	40	32
150/4	150	154	4	2517	60	2	52	45
150/5	150	154	5	2517	60	2	64	45
150/6	150	154	6	2517	60	2	76	45
150/8	150	154	8	2517	60	3	100	45
SPZ 160/1	160	164	1	1610	42	1	16	25
160/2	160	164	2	2012	50	1	28	32
160/3	160	164	3	2012	50	2	40	32
160/4	160	164	4	2517	60	2	52	45
160/5	160	164	5	2517	60	2	64	45
160/6	160	164	6	2517	60	2	76	45
160/8	160	164	8	2517	60	3	100	45
SPZ 170/1	170	174	1	1610	42	1	16	25
170/2	170	174	2	2012	50	1	28	32
170/3	170	174	3	2012	50	3	40	32
170/4	170	174	4	2517	60	2	52	45
170/5	170	174	5	2517	60	2	64	45
170/6	170	174	6	2517	60	2	76	45
SPZ 180/1	180	184	1	1610	42	7	16	25
180/2	180	184	2	2012	50	7	28	32
180/3	180	184	3	2012	50	6	40	32
180/4	180	184	4	2517	60	2	52	45
180/5	180	184	5	2517	60	2	64	45
180/6	180	184	6	2517	60	3	76	45
180/8	180	184	8	2517	60	3	100	45
SPZ 190/1	190	194	1	1610	42	7	16	25
190/2	190	194	2	2012	50	7	28	32
190/3	190	194	3	2012	50	6	40	32
190/4	190	194	4	2517	60	3	52	45
190/5	190	194	5	2517	60	3	64	45
190/6	190	194	6	2517	60	3	76	45
SPZ 200/1	200	204	1	2012	50	7	16	32
200/2	200	204	2	2012	50	7	28	32
200/3	200	204	3	2012	50	6	40	32
200/4	200	204	4	2517	60	6	52	45
200/5	200	204	5	2517	60	3	64	45
200/6	200	204	6	2517	60	3	76	45

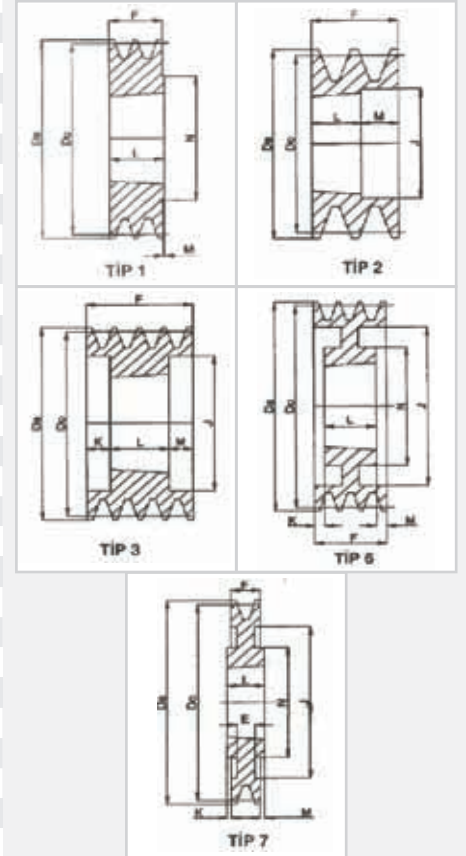

BURÇLU V KASNAKLAR
V PULLEYS FOR TAPER BUSHES
SPZ (10 mm) BURÇLU V KASNAKLAR / SPZ (10 mm) V PULLEYS FOR TAPER BUSHES

Birim / Unit : mm

Kod Code	Anma Çapı Nominal Dia. Do	Dış Çapı Outer Dia. Da	Kanal No Groove	Burç No Bush	Max. Delik Max. Bore	Kasnak Tipi Pulley Type	F	L
SPZ 224/1	224	228	1	2012	50	7	16	32
224/2	224	228	2	2012	50	7	28	32
224/3	224	228	3	2012	50	6	40	32
224/4	224	228	4	2517	60	6	52	45
224/5	224	228	5	2517	60	6	64	45
224/6	224	228	6	2517	60	6	76	45
224/8	224	228	8	3020	75	3	100	50
SPZ 250/1	250	254	1	2012	50	4	16	32
250/2	250	254	2	2012	50	4	28	32
250/3	250	254	3	2012	50	5	40	32
250/4	250	254	4	2517	60	6	52	45
250/5	250	254	5	2517	60	6	64	45
250/6	250	254	6	2517	60	6	76	45
250/8	250	254	8	3020	75	6	100	50
SPZ 280/1	280	284	1	2012	50	4	16	32
280/2	280	284	2	2012	50	4	28	32
280/3	280	284	3	2517	50	4	40	45
280/4	280	284	4	2517	60	6	52	45
280/5	280	284	5	2517	60	6	64	45
280/6	280	284	6	2517	60	6	76	45
280/8	280	284	8	3020	75	6	100	50
SPZ 315/1	315	319	1	2012	50	4	16	32
315/2	315	319	2	2012	50	4	28	32
315/3	315	319	3	2517	60	4	40	45
315/4	315	319	4	2517	60	5	52	45
315/5	315	319	5	2517	60	5	64	45
315/6	315	319	6	2517	60	6	76	45
SPZ 355/1	355	359	1	2012	50	4	16	32
355/2	355	359	2	2012	50	4	28	32
355/3	355	359	3	2517	60	4	40	45
355/4	355	359	4	2517	60	5	52	45
355/5	355	359	5	2517	60	5	64	45
355/6	355	359	6	2517	60	5	76	45
355/8	355	359	8	3030	75	5	100	76
SPZ 400/1	400	404	1	2012	50	4	16	32
400/2	400	404	2	2517	60	4	28	45
400/3	400	404	3	2517	60	4	40	45
400/4	400	404	4	2517	60	5	52	45
400/5	400	404	5	3020	75	5	64	50
400/6	400	404	6	3030	75	5	76	76
400/8	400	404	8	3030	75	5	100	76
SPZ 450/1	450	454	1	2517	60	4	16	45
450/2	450	454	2	2517	60	4	28	45
450/3	450	454	3	2517	60	4	40	45
450/4	450	454	4	3020	75	5	52	50
450/5	450	454	5	3020	75	5	64	50
450/6	450	454	6	3030	75	5	76	76
450/8	450	454	8	3535	90	5	100	91

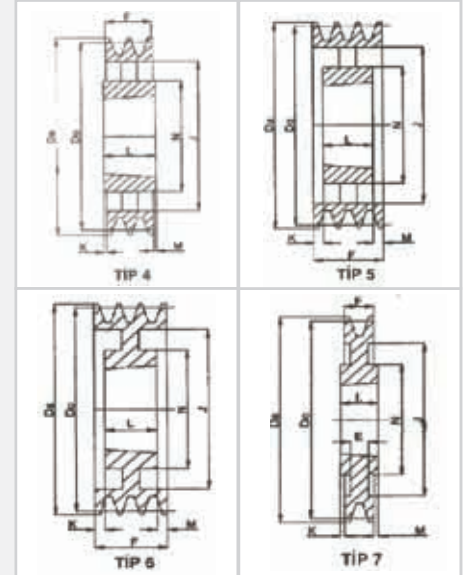

BURÇLU V KASNAKLAR
V PULLEYS FOR TAPER BUSHES
SPA (13 mm) BURÇLU V KASNAKLAR / SPA (13 mm) V PULLEYS FOR TAPER BUSHES

Birim / Unit : mm

Kod Code	Anma Çapı Nominal Dia. Do	Dış Çapı Outer Dia. Da	Kanal No Groove	Burç No Bush	Max. Delik Max. Bore	Kasnak Tipi Pulley Type	F	L
SPA 63/1	63	68.5	1	1108	28	1	40	22
63/2	63	68.5	2	1108	28	8	55	22
SPA 67/1	67	72.5	1	1108	28	1	20	22
67/2	67	72.5	2	1108	28	8	35	22
SPA 71/1	71	76.5	1	1108	28	1	20	22
71/2	71	76.5	2	1108	28	8	35	22
71/3	71	76.5	3	1108	28	8	50	22
SPA 75/1	75	80.5	1	1108	28	1	20	22
75/2	75	80.5	2	1108	28	8	35	22
75/3	75	80.5	3	1108	28	8	50	22
SPA 80/1	80	85.5	1	1108	28	1	20	22
80/2	80	85.5	2	1108	28	8	35	22
80/3	80	85.5	3	1108	28	8	50	22
SPA 85/1	85	90.5	1	1210	32	1	20	25
85/2	85	90.5	2	1210	32	8	35	25
85/3	85	90.5	3	1210	32	8	50	25
SPA 90/1	90	95.5	1	1210	32	1	20	25
90/2	90	95.5	2	1610	42	8	35	25
90/3	90	95.5	3	1610	42	8	50	25
90/4	90	95.5	4	1610	42	8	65	38
SPA 95/1	95	100.5	1	1210	32	1	20	25
95/2	95	100.5	2	1610	42	8	35	25
95/3	95	100.5	3	1610	42	8	50	25
95/4	95	100.5	4	1615	42	8	65	38
SPA100/1	100	105.5	1	1610	42	1	20	25
100/2	100	105.5	2	1610	42	8	35	25
100/3	100	105.5	3	1610	42	2	50	25
100/4	100	105.5	4	1615	42	2	65	38
100/5	100	105.5	5	1615	42	2	80	38
100/6	100	105.5	6	1615	42	3	95	38
SPA 106/1	106	111.5	1	1610	42	1	20	25
106/2	106	111.5	2	1610	42	8	35	25
106/3	106	111.5	3	1610	42	2	50	25
106/4	106	111.5	4	2012	50	8	65	32
106/5	106	111.5	5	2012	50	8	80	32
106/6	106	111.5	6	2012	50	8	95	32
SPA 112/1	112	117.5	1	1610	42	1	20	25
112/2	112	117.5	2	1610	42	8	35	25
112/3	112	117.5	3	2012	50	8	50	32
112/4	112	117.5	4	2012	50	8	65	32
112/5	112	117.5	5	2012	50	8	80	32
112/6	112	117.5	6	2012	50	8	95	32
SPA 118/1	118	123.5	1	1610	42	1	20	25
118/2	118	123.5	2	1610	42	8	35	25
118/3	118	123.5	3	2012	50	2	50	32
118/4	118	123.5	4	2012	50	2	65	32
118/5	118	123.5	5	2012	50	2	80	32
118/6	118	123.5	6	2012	50	8	95	32
SPA 125/1	125	130.5	1	1610	42	1	20	25
125/2	125	130.5	2	1610	42	8	35	25
125/3	125	130.5	3	2012	50	2	50	32
125/4	125	130.5	4	2012	50	2	65	32
125/5	125	130.5	5	2012	50	3	80	32
125/6	125	130.5	6	2012	50	3	95	32

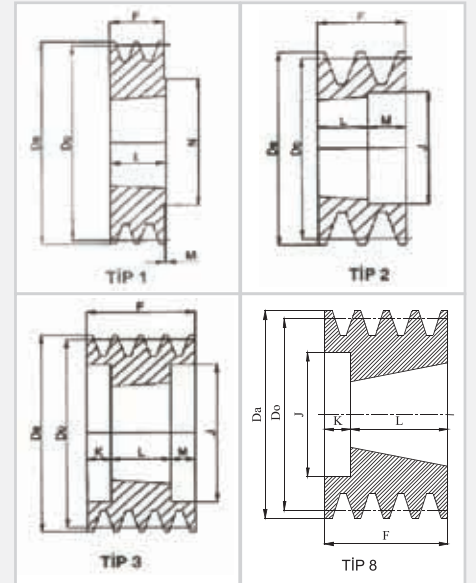

BURÇLU V KASNAKLAR
V PULLEYS FOR TAPER BUSHES

SPA (13 mm) BURÇLU V KASNAKLAR / SPA (13 mm) V PULLEYS FOR TAPER BUSHES

Birim / Unit : mm

Kod Code	Anma Çapı Nominal Dia. Do	Dış Çapı Outer Dia. Da	Kanal No Groove	Burç No Bush	Max. Delik Max. Bore	Kasnak Tipi Pulley Type	F	L
SPA 132/1	132	137.5	1	1610	42	1	20	25
132/2	132	137.5	2	2012	50	8	35	32
132/3	132	137.5	3	2012	50	2	50	32
132/4	132	137.5	4	2517	60	2	65	45
132/5	132	137.5	5	2517	60	3	80	45
132/6	132	137.5	6	2517	60	3	95	45
SPA 140/1	140	145.5	1	1610	42	1	20	25
140/2	140	145.5	2	2012	50	8	35	32
140/3	140	145.5	3	2517	60	8	50	32
140/4	140	145.5	4	2517	60	2	65	45
140/5	140	145.5	5	2517	60	3	80	45
140/6	140	145.5	6	2517	60	3	95	45
SPA 150/1	150	155.5	1	1610	42	1	20	25
150/2	150	155.5	2	2012	50	8	35	32
150/3	150	155.5	3	2517	60	8	50	32
150/4	150	155.5	4	2517	60	2	65	45
150/5	150	155.5	5	2517	60	3	80	45
150/6	150	155.5	6	2517	60	3	95	45
SPA 160/1	160	165.5	1	1610	42	1	20	25
160/2	160	165.5	2	2012	50	8	35	32
160/3	160	165.5	3	2517	60	8	50	32
160/4	160	165.5	4	2517	60	2	65	45
160/5	160	165.5	5	2517	60	3	80	45
160/6	160	165.5	6	2517	60	3	95	45
SPA 170/1	170	175.5	1	1610	42	1	20	25
170/2	170	175.5	2	2012	50	8	35	32
170/3	170	175.5	3	2517	60	8	50	45
170/4	170	175.5	4	2517	60	2	60	45
SPA 180/1	180	185.5	1	1610	50	7	20	25
180/2	180	185.5	2	2012	60	6	35	32
180/3	180	185.5	3	2517	60	8	50	45
180/4	180	185.5	4	2517	75	2	65	45
180/5	180	185.5	5	3020	75	3	80	51
180/6	180	185.5	6	3020	75	3	95	51
SPA 190/1	190	195.5	1	1610	42	7	20	25
190/2	190	195.5	2	2012	50	6	35	32
190/3	190	195.5	3	2517	60	8	50	45
190/4	190	195.5	4	2517	60	2	65	45
SPA 200/1	200	205.5	1	2012	50	7	20	32
200/2	200	205.5	2	2517	60	7	35	45
200/3	200	205.5	3	2517	60	6	50	45
200/4	200	205.5	4	3020	75	2	65	51
200/5	200	205.5	5	3020	75	3	80	51
200/6	200	205.5	6	3020	75	3	95	51
SPA 224/1	224	229.5	1	2012	50	7	20	32
224/2	224	229.5	2	2517	60	7	35	45
224/3	224	229.5	3	2517	60	6	50	45
224/4	224	229.5	4	3020	75	6	65	51
224/5	224	229.5	5	3020	75	2	80	51
224/6	224	229.5	6	3020	75	3	95	51
SPA 236/1	236	241.5	1	2012	50	7	20	32
236/2	236	241.5	2	2517	60	7	35	45
236/3	236	241.5	3	2517	60	6	50	45
236/4	236	241.5	4	3020	75	6	65	51
236/5	236	241.5	5	3020	75	2	80	51

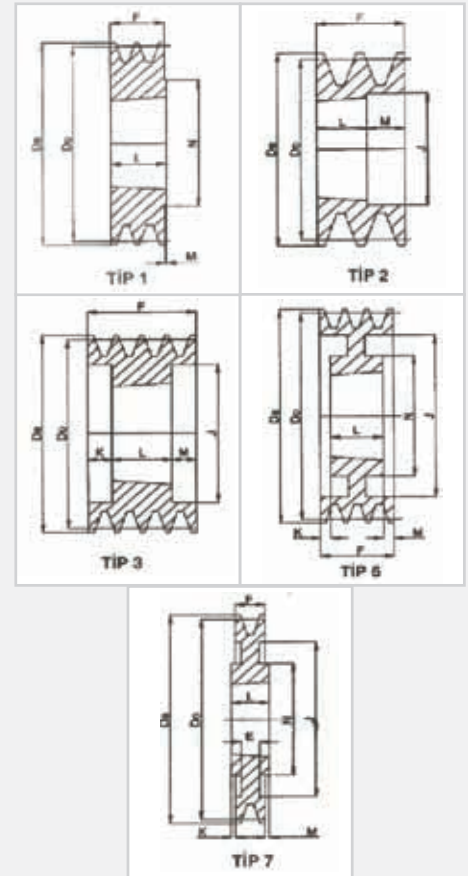

BURÇLU V KASNAKLAR
V PULLEYS FOR TAPER BUSHES
SPA (13 mm) BURÇLU V KASNAKLAR / SPA (13 mm) V PULLEYS FOR TAPER BUSHES

Birim / Unit : mm

Kod Code	Anma Çapı Nominal Dia. Do	Dış Çapı Outer Dia. Da	Kanal No Groove	Burç No Bush	Max. Delik Max. Bore	Kasnak Tipi Pulley Type	F	L
SPA 250/1	250	255.5	1	2012	50	7	20	32
250/2	250	255.5	2	2517	60	7	35	45
250/3	250	255.5	3	2517	60	6	50	45
250/4	250	255.5	4	3020	75	6	65	51
250/5	250	255.5	5	3020	75	6	80	51
250/6	250	255.5	6	3020	75	6	95	51
SPA 280/1	280	285.5	1	2012	50	7	20	32
280/2	280	285.5	2	2517	60	7	35	45
280/3	280	285.5	3	2517	60	6	50	45
280/4	280	285.5	4	3020	75	6	65	51
280/5	280	285.5	5	3535	90	7	80	89
280/6	280	285.5	6	3535	90	6	95	89
SPA 300/1	300	305.5	1	2012	50	7	20	32
300/2	300	305.5	2	2517	60	7	35	45
300/3	300	305.5	3	3020	75	7	50	51
300/4	300	305.5	4	3020	75	6	65	51
300/5	300	305.5	5	3535	90	7	80	89
SPA 315/1	315	320.5	1	2012	50	4	20	32
315/2	315	320.5	2	2517	60	7	35	45
315/3	315	320.5	3	3020	75	4	50	51
315/4	315	320.5	4	3020	75	6	65	51
315/5	315	320.5	5	3535	90	7	80	89
315/6	315	320.5	6	3535	90	6	95	89
SPA 355/1	355	360.5	1	2012	50	4	20	32
355/2	355	360.5	2	2517	60	4	35	45
355/3	355	360.5	3	3020	75	4	50	51
355/4	355	360.5	4	3020	75	5	60	51
355/5	355	360.5	5	3535	90	4	80	89
355/6	355	360.5	6	3535	90	5	95	89
SPA 400/1	400	405.5	1	2012	50	4	20	32
400/2	400	405.5	2	2517	60	4	35	45
400/3	400	405.5	3	3020	75	4	50	51
400/4	400	405.5	4	3020	75	5	65	51
400/5	400	405.5	5	3535	90	4	80	89
400/6	400	405.5	6	3535	90	5	95	89
SPA 450/1	450	455.5	1	2012	50	4	20	32
450/2	450	455.5	2	2517	60	4	35	45
450/3	450	455.5	3	3020	75	4	50	51
450/4	450	455.5	4	3020	75	5	65	51
450/5	450	455.5	5	3535	90	4	80	89
450/6	450	455.5	6	3535	90	5	95	89
SPA 500/1	500	505.5	1	2012	50	4	20	45
500/2	500	505.5	2	2517	60	4	35	45
500/3	500	505.5	3	3020	75	4	50	51
500/4	500	505.5	4	3020	75	5	65	51
500/5	500	505.5	5	3535	90	4	80	89
500/6	500	505.5	6	3535	90	5	95	89
SPA 560/2	560	565.5	2	3020	75	4	35	51
560/3	560	565.5	3	3020	75	4	50	51
560/4	560	565.5	4	3535	90	4	65	89
560/5	560	565.5	5	3535	90	4	80	89
560/6	560	565.5	6	3535	90	5	95	89

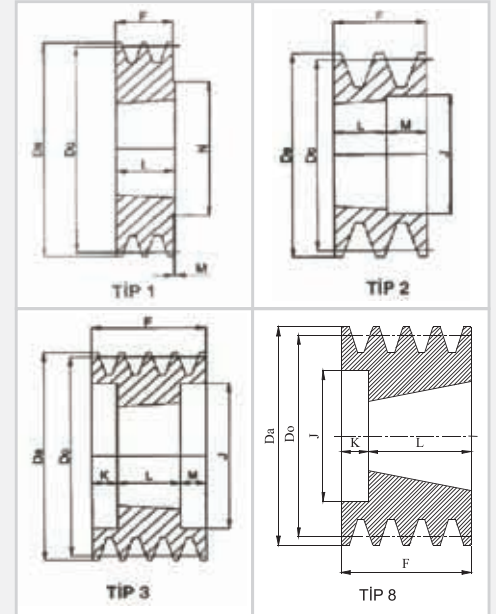

BURÇLU V KASNAKLAR
V PULLEYS FOR TAPER BUSHES

SPB (17 mm) BURÇLU V KASNAKLAR / SPB (17 mm) V PULLEYS FOR TAPER BUSHES

Birim / Unit : mm

Kod Code	Anma Çapı Nominal Dia. Do	Dış Çapı Outer Dia. Da	Kanal No Groove	Burç No Bush	Max. Delik Max. Bore	Kasnak Tipi Pulley Type	F	L
SPB100/1	100	107	1	1610	42	1	25	25
100/2	100	107	2	1610	42	8	44	25
100/3	100	107	3	1610	42	8	63	25
SPB112/1	112	119	1	1610	42	1	25	25
112/2	112	119	2	1610	42	8	44	25
112/3	112	119	3	1610	42	8	63	25
SPB118/1	118	125	1	1610	42	1	25	25
118/2	118	125	2	1610	42	2	44	25
118/3	118	125	3	1610	42	2	63	25
SPB125/1	125	132	1	1610	42	1	25	25
125/2	125	132	2	2012	50	2	44	32
125/3	125	132	3	2012	50	2	63	32
125/4	125	132	4	2012	50	3	82	32
125/5	125	132	5	2012	50	8	101	32
SPB132/1	132	139	1	1610	42	1	25	25
132/2	132	139	2	2012	50	2	44	32
132/3	132	139	3	2012	50	2	63	32
132/4	132	139	4	2012	50	3	82	32
132/5	132	139	5	2517	60	8	101	45
SPB140/1	140	147	1	1610	42	1	25	25
140/2	140	147	2	2012	50	2	44	32
140/3	140	147	3	2012	50	2	63	32
140/4	140	147	4	2517	60	3	82	45
140/5	140	147	5	2517	60	3	101	45
140/6	140	147	6	2517	60	3	120	45
SPB150/1	150	157	1	1610	42	1	25	25
150/2	150	157	2	2012	50	2	44	32
150/3	150	157	3	2517	60	2	63	45
150/4	150	157	4	2517	60	3	82	45
150/5	150	157	5	2517	60	3	101	45
150/6	150	157	6	2517	60	3	120	45
SPB160/1	160	167	1	1610	42	1	25	25
160/2	160	167	2	2012	50	2	44	32
160/3	160	167	3	2517	60	2	63	45
160/4	160	167	4	2517	60	3	82	45
160/5	160	167	5	2517	60	3	101	45
160/6	160	167	6	3020	75	3	120	51
160/8	160	167	8	3020	75	3	158	51
SPB170/1	170	177	1	1610	42	1	25	25
170/2	170	177	2	2012	50	2	44	32
170/3	170	177	3	2517	60	2	63	45
170/4	170	177	4	2517	60	3	82	45
170/5	170	177	5	3020	75	3	101	51
170/6	170	177	6	3020	75	3	120	51
170/8	170	177	8	3020	75	3	158	76

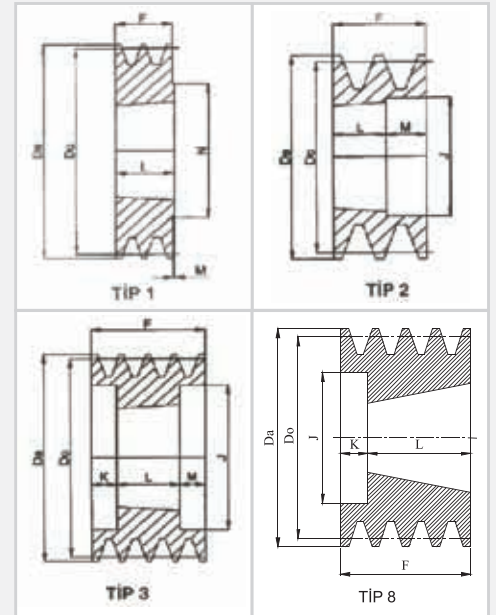

BURÇLU V KASNAKLAR
V PULLEYS FOR TAPER BUSHES
SPB (17 mm) BURÇLU V KASNAKLAR / SPB (17 mm) V PULLEYS FOR TAPER BUSHES

Birim / Unit : mm

Kod Code	Anma Çapı Nominal Dia. Do	Dış Çapı Outer Dia. Da	Kanal No Groove	Burç No Bush	Max. Delik Max. Bore	Kasnak Tipi Pulley Type	F	L
SPB180/1	180	187	1	1610	42	6	25	25
180/2	180	187	2	2517	60	1	44	45
180/3	180	187	3	2517	60	2	63	45
180/4	180	187	4	2517	60	3	82	45
180/5	180	187	5	3020	75	3	101	51
180/6	180	187	6	3020	75	3	120	51
180/8	180	187	8	3020	75	3	158	76
SPB190/1	190	197	1	2012	50	7	25	32
190/2	190	197	2	2517	60	1	44	45
190/3	190	197	3	2517	60	2	63	45
190/4	190	197	4	2517	60	3	82	45
190/5	190	197	5	3020	75	3	101	51
190/6	190	197	6	3020	75	3	120	51
190/8	190	197	8	3020	75	3	158	75
SPB 200/1	200	207	1	2012	50	7	25	32
200/2	200	207	2	2517	60	1	44	45
200/3	200	207	3	2517	60	2	63	45
200/4	200	207	4	2517	75	3	82	51
200/5	200	207	5	3020	75	3	101	51
200/6	200	207	6	3020	75	3	120	51
200/8	200	207	8	3535	90	3	158	89
SPB 212/1	212	219	1	2012	50	7	25	32
212/2	212	219	2	2517	60	7	44	45
212/3	212	219	3	2517	60	6	63	45
212/4	212	219	4	2517	75	3	82	51
212/5	212	219	5	3020	75	3	101	51
212/6	212	219	6	3020	75	3	120	89
212/8	212	219	8			3	158	89
SPB 224/1	224	231	1	2012	50	7	25	32
224/2	224	231	2	2517	60	7	44	45
224/3	224	231	3	2517	60	6	63	45
224/4	224	231	4	3020	75	3	82	51
224/5	224	231	5	3020	75	3	101	51
224/6	224	231	6	3535	90	3	120	89
224/8	224	231	8	3535	90	3	158	89
224/10	224	231	10	3535	90	3	196	89
SPB 236/1	236	243	1	2012	50	7	25	32
236/2	236	243	2	2517	60	7	44	45
236/3	236	243	3	2517	60	6	63	45
236/4	236	243	4	3020	75	3	82	51
236/5	236	243	5	3020	90	3	101	51
236/6	236	243	6	3535	90	3	120	89
236/8	236	243	8	3535	90	3	158	89
236/10	236	243	10	3535	90	3	196	89
SPB 250/1	250	257	1	2012	50	7	25	32
250/2	250	257	2	2517	60	7	44	45
250/3	250	257	3	3020	75	6	63	51
250/4	250	257	4	3020	75	6	82	51
250/5	250	257	5	3020	90	3	101	51
250/6	250	257	6	3535	90	3	120	89
250/8	250	257	8	3535	90	3	158	89
250/10	250	257	10	3535	90	3	196	89

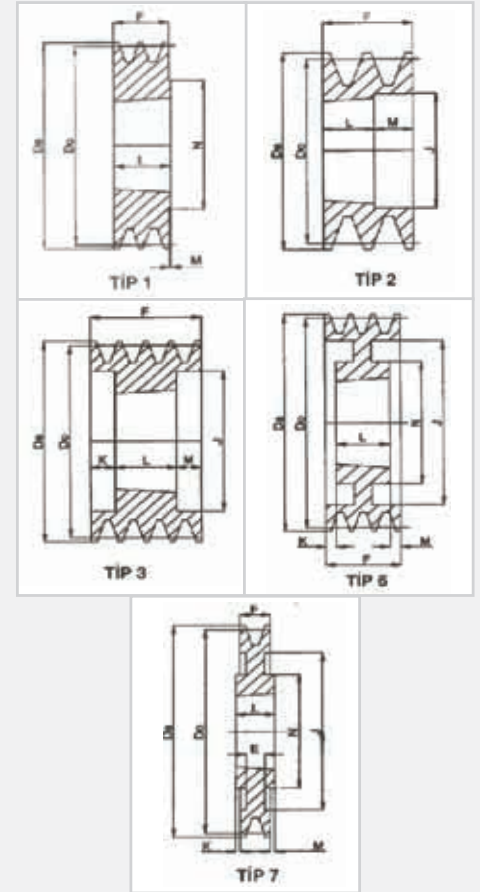



BURÇLU V KASNAKLAR V PULLEYS FOR TAPER BUSHES

SPB (17 mm) BURÇLU V KASNAKLAR / SPB (17 mm) V PULLEYS FOR TAPER BUSHES

Birim / Unit : mm

Kod Code	Anma Çapı Nominal Dia. Do	Dış Çapı Outer Dia. Da	Kanal No Groove	Burç No Bush	Max. Delik Max. Bore	Kasnak Tipi Pulley Type	F	L
SPB 280/1	280	287	1	2012	50	7	25	32
280/2	280	287	2	2517	60	7	44	45
280/3	280	287	3	3020	75	6	63	51
280/4	280	287	4	3020	75	6	82	51
280/5	280	287	5	3535	90	6	101	89
280/6	280	287	6	3535	90	6	120	89
280/8	280	287	8	3535	90	6	158	89
280/10	280	287	10	3535	90	6	196	89
SPB 300/2	300	307	2	2517	60	7	44	45
300/3	300	307	3	3020	75	6	63	51
300/4	300	307	4	3020	75	6	82	51
300/5	300	307	5	3535	90	6	101	89
300/6	300	307	6	3535	90	6	120	89
300/8	300	307	8	3535	90	6	158	89
SPB 315/1	315	322	1	2012	50	7	25	32
315/2	315	322	2	2517	60	7	44	45
315/3	315	322	3	3020	75	6	63	51
315/4	315	322	4	3535	90	7	82	89
315/5	315	322	5	3535	90	6	101	89
315/6	315	322	6	3535	90	6	120	89
315/8	315	322	8	3535	90	6	158	89
315/10	315	322	10	3535	90	6	196	89
SPB 335/2	335	342	1	3020	75	7	44	51
335/3	335	342	2	3020	75	6	63	51
335/4	335	342	3	3535	90	7	82	89
335/5	335	342	4	3535	90	6	101	89
335/6	335	342	5	3535	90	6	120	89
335/8	335	342	6	3535	90	6	158	89
335/10	335	342	8	4040	100	6	196	102
SPB 355/2	355	362	2	3020	75	4	44	51
355/3	355	362	3	3020	75	5	63	51
355/4	355	362	4	3535	90	7	82	89
355/5	355	362	5	3535	90	5	101	89
355/6	355	362	6	3535	90	6	120	89
355/8	355	362	8	3535	90	6	158	89
355/10	355	362	10	4040	100	6	196	102
SPB 400/2	400	407	2	3020	75	4	44	51
400/3	400	407	3	3535	90	4	63	89
400/4	400	407	4	3535	90	4	82	89
400/5	400	407	5	3535	90	5	101	89
400/6	400	407	6	3535	90	5	120	89
400/8	400	407	8	3535	100	6	158	102
400/10	400	407	10	4040	100	6	196	102
SPB 450/2	450	457	2	3020	75	4	44	51
450/3	450	457	3	3535	90	4	63	89
450/4	450	457	4	3535	90	4	82	89
450/5	450	457	5	3535	90	5	101	89
450/6	450	457	6	4040	100	5	120	102
450/8	450	457	8	4040	100	5	158	102
450/10	450	457	10	4040	100	5	196	114

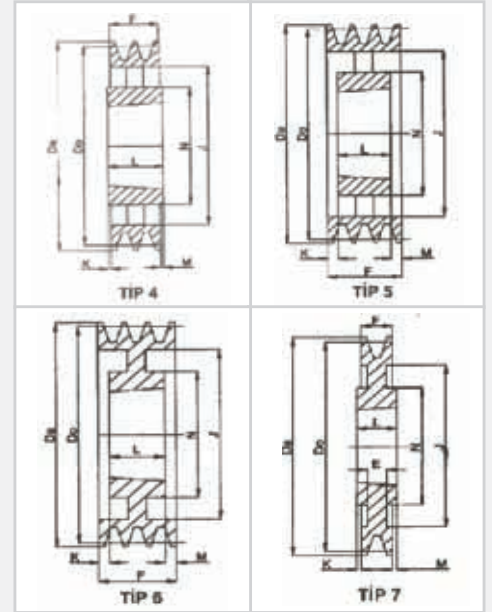

BURÇLU V KASNAKLAR
V PULLEYS FOR TAPER BUSHES
SPC (22 mm) BURÇLU V KASNAKLAR / SPC (22 mm) V PULLEYS FOR TAPER BUSHES

Birim / Unit : mm

Kod Code	Anma Çapı Nominal Dia. Do	Dış Çapı Outer Dia. Da	Kanal No Groove	Burç No Bush	Max. Delik Max. Bore	Kasnak Tipi Pulley Type	F	L
SPC 140/2	140	149.6	2	2012		2	60	30
140/3	140	149.6	3	2012		3	85	30
SPC 150/2	150	159.6	2	2012		2	60	30
150/3	150	159.6	3	2517		2	85	45
SPC 190/2	190	199.6	2	2517		2	60	45
190/3	190	199.6	3	2517		3	85	45
190/4	190	199.6	4	3020		4	111	51
190/5	190	199.6	5	3020		5	136	51
SPC 200/3	200	209.6	3	2517	60	3	85	45
200/4	200	209.6	4	3020	75	3	111	51
200/5	200	209.6	5	3535	90	3	136	89
200/6	200	209.6	6	3535	90	3	162	89
200/8	200	209.6	8	3535	90	3	213	89
SPC 212/3	212	221.6	3	3020	75	3	85	51
212/4	212	221.6	4	3020	75	3	111	51
212/5	212	221.6	5	3535	90	3	136	89
212/6	212	221.6	6	3535	90	3	162	89
212/8	212	221.6	8	3535	90	3	213	89
SPC 224/2	224	233.6	2	3020	75	3	60	51
224/3	224	233.6	3	3020	75	3	85	51
224/4	224	233.6	4	3535	90	3	111	89
224/5	224	233.6	5	3535	90	3	136	89
224/6	224	233.6	6	3535	90	3	162	89
224/8	224	233.6	8	3535	90	3	213	89
SPC 236/3	236	245.6	3	3020	75	3	85	51
236/4	236	245.6	4	3535	90	3	111	89
236/5	236	245.6	5	3535	90	3	136	89
236/6	236	245.6	6	3535	90	3	162	89
236/8	236	245.6	8	3535	90	3	213	89
SPC 250/2	250	259.6	2	3020	75	3	60	51
250/3	250	259.6	3	3020	75	3	85	51
250/4	250	259.6	4	3535	90	3	111	89
250/5	250	259.6	5	3535	90	3	136	89
250/6	250	259.6	6	3535	90	3	162	89
250/8	250	259.6	8	3535	90	3	213	89
250/10	250	259.6	10	4040	100	3	264	102
SPC 265/3	265	274.6	3	3535	90	1	85	89
265/4	265	274.6	4	3535	90	3	111	89
265/5	265	274.6	5	3535	90	3	136	89
265/6	265	274.6	6	3535	90	3	162	89
265/8	265	274.6	8	3535	90	3	213	89
SPC 280/2	280	289.6	2	3020	75	5	60	51
280/3	280	289.6	3	3535	90	1	85	89
280/4	280	289.6	4	3535	90	6	111	89
280/5	280	289.6	5	3535	90	3	136	89
280/6	280	289.6	6	3535	90	6	162	89
280/8	280	289.6	8	3535	90	3	213	89
280/10	280	289.6	10	4040	100	3	264	102
SPC 300/2	300	309.6	2	3020	75	5	60	51
300/3	300	309.6	3	3535	90	7	85	89
300/4	300	309.6	4	3535	90	6	111	89
300/5	300	309.6	5	3535	90	6	136	89
300/6	300	309.6	6	3535	90	6	162	89
300/8	300	309.6	8	4040	100	3	213	102

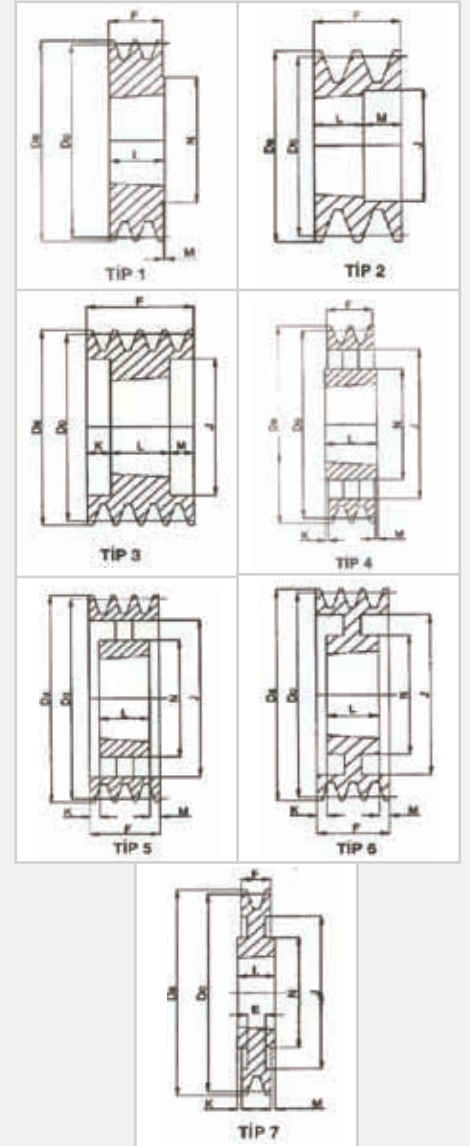

BURÇLU V KASNAKLAR
V PULLEYS FOR TAPER BUSHES
SPC (22 mm) BURÇLU V KASNAKLAR / SPC (22 mm) V PULLEYS FOR TAPER BUSHES

Birim / Unit : mm

Kod Code	Anma Çapı Nominal Dia. Do	Dış Çapı Outer Dia. Da	Kanal No Groove	Burç No Bush	Max. Delik Max. Bore	Kasnak Tipi Pulley Type	F	L
SPC 315/3	315	324.6	3	3535	90	7	85	89
315/4	315	324.6	4	3535	90	6	111	89
315/5	315	324.6	5	3535	90	6	136	89
315/6	315	324.6	6	3535	90	6	162	89
315/8	315	324.6	8	4040	100	3	213	102
315/10	315	324.6	10	4545	110	3	264	114
SPC 335/2	335	344.6	2	3020	75	5	60	51
335/3	335	344.6	3	3535	90	7	85	89
335/4	335	344.6	4	3535	90	6	111	89
335/5	335	344.6	5	3535	90	6	136	89
335/6	335	344.6	6	3535	90	6	162	89
335/8	335	344.6	8	4040	100	6	213	102
SPC 355/3	355	364.6	3	3535	90	7	85	89
355/4	355	364.6	4	3535	90	6	111	89
355/5	355	364.6	5	3535	90	6	136	89
355/6	355	364.6	6	3535	90	6	162	89
355/8	355	364.6	8	4040	100	6	213	102
355/10	355	364.6	10	4545	110	3	264	114
SPC 375/3	375	384.6	3	3535	90	7	85	89
375/4	375	384.6	4	3535	90	6	111	89
375/5	375	384.6	5	3535	90	6	136	89
375/6	375	384.6	6	4040	100	6	162	102
375/8	375	384.6	8	4545	110	6	213	114
SPC 400/2	400	409.6	2	3020	75	5	60	51
400/3	400	409.6	3	3535	90	7	85	89
400/4	400	409.6	4	3535	90	6	111	89
400/5	400	409.6	5	3535	90	6	136	89
400/6	400	409.6	6	4040	100	6	162	102
400/8	400	409.6	8	4545	110	6	213	114
400/10	400	409.6	10	5050	125	6	264	127
SPC 425/3	425	434.6	3	3535	90	7	85	89
425/4	425	434.6	4	3535	90	6	111	89
425/5	425	434.6	5	4040	100	6	136	102
425/6	425	434.6	6	4545	110	6	162	114
425/8	425	434.6	8	5050	125	6	213	127
SPC 450/3	450	459.6	3	3535	90	4	85	89
450/4	450	459.6	4	3535	90	5	111	89
450/5	450	459.6	5	4040	100	5	136	102
450/6	450	459.6	6	4545	110	6	162	114
450/8	450	459.6	8	5050	125	6	213	127
450/10	450	459.6	10	5050	125	6	264	127
SPC 475/3	475	484.6	3	3535	90	4	85	89
475/4	475	484.6	4	3535	90	5	111	89
475/5	475	484.6	5	4040	100	5	136	102
475/6	475	484.6	6	4545	110	6	162	114
475/8	475	484.6	8	5050	125	6	213	127

